

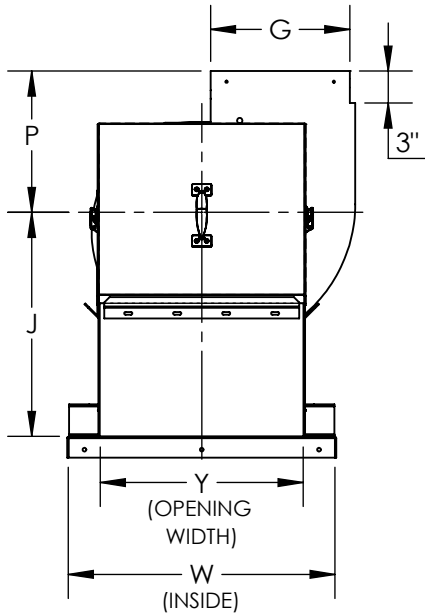

DATE: TAG:
 JOB:
 PROJECT:
 COMPANY:
 SALES PERSON:

UVS2, CLASS-1, ARRANGEMENT- 4
 INLET BOX AND CURB CAP, SIZES 60-270



INLET VIEW

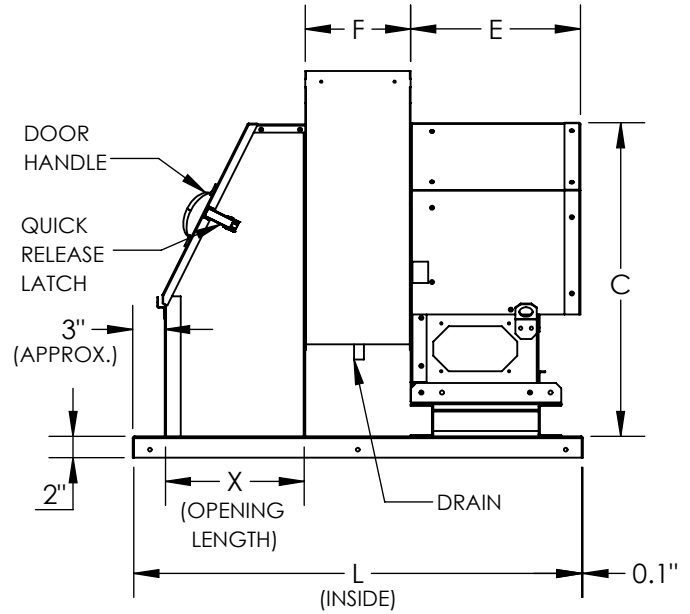

STANDARD CONSTRUCTION:

1. Discharge: UB
2. Rotation: CW/CCW (CW shown above)
3. Steel Wheel
4. Welded and Coated Housing, Bolted and Galvanized Pedestal.
5. Welded and Coated Inlet Box and Curb Cap
6. Weather Cover
7. Housing Drain & Plug - 3/4" NPT

OPTIONAL ACCESSORIES:

1. Speed Controllers (shipped loose only)
2. Flanged Outlet
3. Shaft Seal
4. Outlet Screen
5. Disconnect Switch
6. Grease Containment
7. Curb
8. Outlet Stack (outlet flange required)
9. Spark Resistant Const. (Type B/C)
10. Piezo Ring
11. Pressure Transducer
12. Access Door (Bolted or Hinged)

DIMENSIONAL DATA

SIZE	C	E	F			G	J	L	P	W	X	Y	MAX. WT. (lbs)	MAX. RPM	MAX. MTR
			100% W	80% W	50% W										
60	28.00	13.00	8.19	-	-	11.56	21.00	39.00	11.75	22.00	11.50	16.00	169	4400	145T
70	28.00	13.00	8.19	-	-	11.56	21.00	39.00	11.75	22.00	11.50	16.00	169	4400	145T
80	28.00	13.00	8.19	-	-	11.56	21.00	39.00	11.75	22.00	11.50	16.00	169	4400	145T
105	28.00	13.00	8.19	-	-	11.56	21.00	39.00	11.75	22.00	11.50	16.00	169	4400	145T
122	29.38	15.94	9.88	9.25	-	13.06	21.00	42.00	13.25	25.00	13.00	19.00	205	3550	182T
135	30.25	15.94	10.88	10.19	-	14.38	21.38	44.00	14.00	28.00	13.00	22.00	229	3222	182T
150	32.63	15.91	12.06	11.31	-	15.88	23.00	46.00	14.50	30.00	13.00	24.00	259	2900	184T
165	35.13	18.00	13.25	12.44	-	17.56	24.63	50.00	14.50	33.00	16.00	27.00	307	2636	213T
182	38.13	20.44	14.06	13.06	11.63	20.06	26.63	53.00	14.75	35.00	17.50	29.00	348	2300	213T
200	41.44	20.44	15.38	14.38	12.75	22.00	28.75	57.00	16.00	38.00	20.50	32.00	444	2100	213T
222	45.00	20.44	17.13	16.00	14.13	24.50	31.25	63.00	17.75	42.00	22.00	36.00	548	1888	215T
245	48.50	23.19	18.75	17.50	15.63	27.00	33.75	67.00	19.50	45.00	24.00	39.00	652	1714	254T
270	52.63	23.19	20.63	19.38	17.13	29.75	36.75	70.00	21.50	48.00	22.50	42.00	746	1556	254T

ALL DIMENSIONS ARE IN INCHES, WEIGHTS ARE APPROXIMATE AND DOES NOT INCLUDE DRIVES OR ACCESSORIES.

REVISION:

FORM:

REPLACES: